

BUS CONTROLLED NTSC/PAL TV PROCESSOR

ADVANCE DATA

- I²C BUS CONTROL OF ALL FUNCTIONS
- INTEGRATED FILTERS (TRAP, BANDPASS)
- INTEGRATED LUMINANCE DELAY LINE
- NTSC CHROMA DEMODULATORS WITH AUTOMATIC FLESH TONE
- PAL DEMODULATORS
- AUTOMATIC CUT-OFF CURRENT LOOP
- ONE RGB INPUT
- SVHS SWITCH
- TWO PLLs HORIZONTAL DEFLECTION
- VERTICAL COUNT DOWN
- XRAY PROTECTION
- BLACK STRETCH
- BLUE SCREEN
- VERY FEW EXTERNAL COMPONENTS

Used with STV8223 (PIF/SIF/switches), TDA1771 or TDA8174 (frame booster), STV2180 (delay line), it allows to design a PAL/NTSC (BGDKIMN) set with very few external components and no adjustment.



DESCRIPTION

The STV2216 is a fully bus controlled IC for TV luma, chroma and deflection processing.

PIN CONNECTIONS

CHROMA/SCANNING GROUND	GND2	1	42	V _{CC2}	CHROMA/SCANNING/BUS SUPPLY
3.58MHz XTAL	CXTL2	2	41	BYO	B-Y OUTPUT
4.43MHz XTAL	CXTL1	3	40	RYO	R-Y OUTPUT
CHROMA LOOP FILTER	CLPF	4	39	RYI	R-Y INPUT
ACC CONTROL CAPACITOR	ACC	5	38	BYI	B-Y INPUT
DATA WIRE FC BUS	SDA	6	37	LFB/SC	LINE FLYBACK INPUT/SANDCASTLE OUTPUT
CLOCK WIRE FC BUS	SCL	7	36	HOUT	HORIZONTAL OUTPUT
FILTER TUNING	FTUN1	8	35	VOUT	VERTICAL OUTPUT
EXTERNAL CRYSTAL SELECTION	ECS	9	34	VAMP	AMPLITUDE CONTROL VOLTAGE
VOLUME AND MUTE CONTROL VOLTAGE	VOL	10	33	SLPF	SCANNING LOOP FILTER
IF STANDARD AND SWITCH SELECTION	SWI	11	32	SXTL	503kHz CERAMIC
OSD EXTERNAL BLUE INPUT	BOSD	12	31	BCL	BEAM CURRENT LIMITER
OSD EXTERNAL GREEN INPUT	GOSD	13	30	ICAT	CATHODE CURRENT MEASUREMENT
OSD EXTERNAL RED INPUT	ROS D	14	29	RO	RED OUTPUT
RGB INSERTION	FBOSD	15	28	GO	GREEN OUTPUT
NOT TO BE CONNECTED	NC	16	27	BO	BLUE OUTPUT
ACC OVERLOAD	ACCO	17	26	CR	RED CUT-OFF CAPACITOR
BLACK STRETCH FILTER	BSC	18	25	CB	BLUE CUT-OFF CAPACITOR
XRAY INPUT	XRAY	19	24	CG	GREEN CUT-OFF CAPACITOR
CVBS OR LUMINANCE INPUT	Y/CVBS	20	23	CHR/SVHS	CHROMINANCE INPUT/SVHS SELECTION
BUS/VIDEO GROUND	GND1	21	22	V _{CC1}	VIDEO SUPPLY

2216-01.EPS

BLOCK DIAGRAM

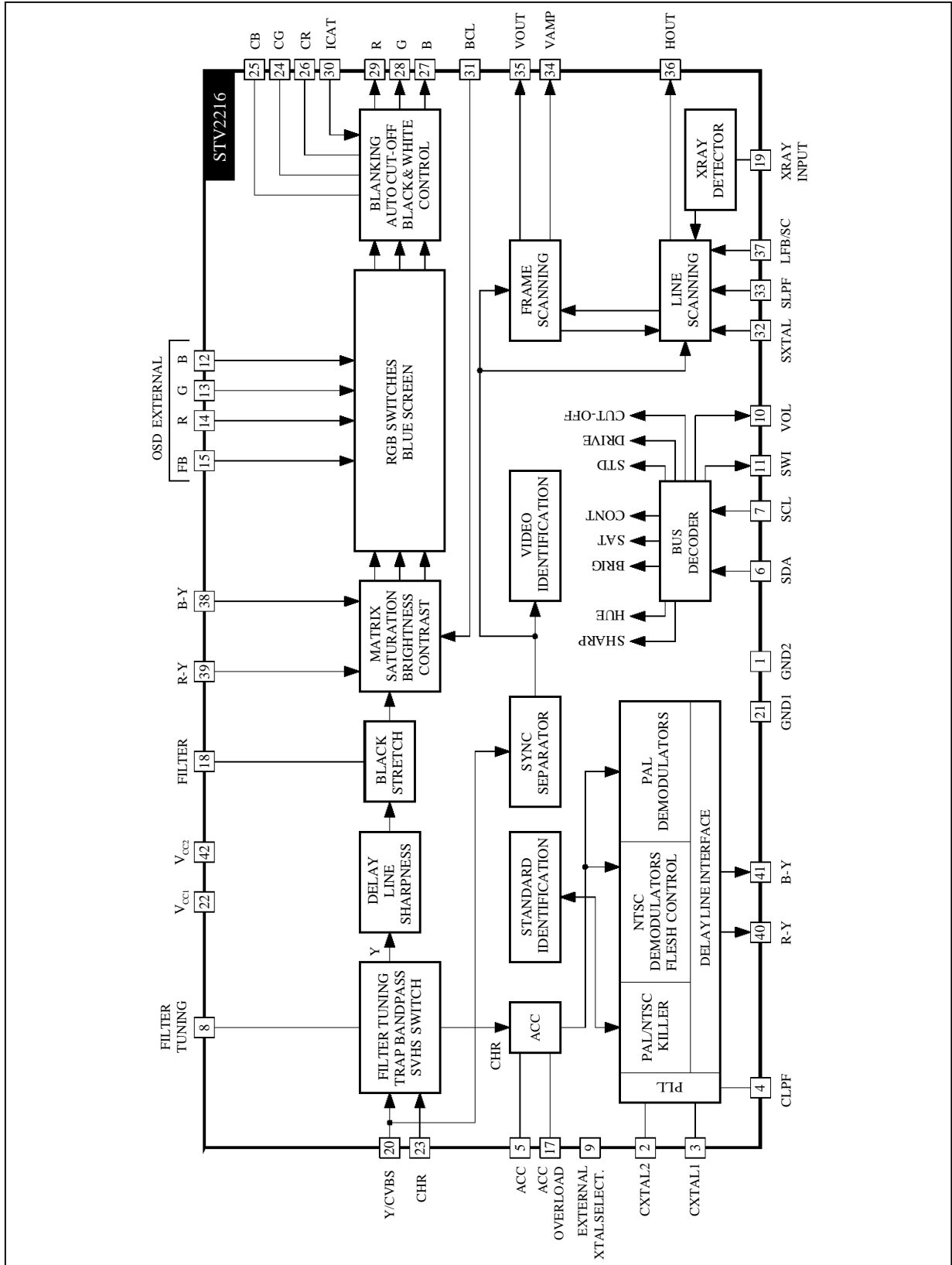

2216-02.EPS

FUNCTIONAL DESCRIPTION

1 - DEFLECTION CIRCUIT (Note : [X,Y] : line number referred to the internal line counter numbering)

- Fully integrated synch. separator, with a low pass filter, a black level alignment of the Y/CVBS input, a slicing level at 2/3, 1/3 of the sync. pulse amplitude.
 - Frame sync. pulse locked on $2 f_H$ frequency to perfect interlace.
 - 500kHz VCO with an external ceramic resonator.
 - Two phase locked loops
 - the first PLL locks the VCO on the video signal frequency,
 - the second PLL compensates the line transistor storage time.
 - Three time constants for the first PLL.
 - the long time constant is used for normal operation
 - the short time constant is automatically used during the frame retrace and in search mode of VCR when the frame pulse is outside [258,264] and [309,314].
 - very long time constant when no video recognition
- Time constants in normal operation
(automatic selection of time constants) :
- 50Hz input signal :
- short time constant : [306, 21]
 - long time constant : the rest of the field
- 60Hz input signal :
- short time constant : [0, 16]
 - long time constant : the rest of the field
 - inhibition of the first PLL :
the first locked loop is opened from line 309 to line 4.5 (or 314) in 50Hz mode. It is opened from line 258 to line 5.5 (or 264) in 60Hz mode.
 - the time constants values are chosen by means of external components.
 - possibility to force the short time constant through the bus.
 - possibility to force the very long time constant through the bus.
- Video identification : coincidence detector between the line synchro top and a line frequency window from the first PLL. The video identification status is available in the output register of the I²C bus decoder.
 - Generation of burst gate pulses and line frequency signals from the first PLL to drive the chroma and video circuits. The burst gate pulse is also sent to the sandcastle generator.
 - Frame synchro window : [248, 352] catching
- Field frequency selection windows :
 - [248, 288] 60Hz mode selection if two consecutive frame pulses occur inside this window, otherwise 50Hz mode selection.
 - [288, 352] 50Hz mode selection window
 - frame blanking pulse :
 - from line 0 to 21 in 50Hz mode
 - from line 0 to 16 in 60Hz mode
 - Vertical output pulse is 10.5 lines long.
 - Horizontal output pulse : 28 μ s line pulse on an open collector output;
 - Start up circuit : the horizontal output is at a high level when V_{CC} increases from 0 to 6.8V. On shutting down, horizontal pulses are disabled when V_{CC} is below 6.2V.
 - Soft-start circuit : the duty cycle of the horizontal output is 78 % (Thigh/(Thigh + TLow)) when V_{CC1} is lower than (0.75 x V_{CC2}), during the rising time. During the falling time, a 78% duty cycle HOUT pulse is provided when V_{CC1} is lower than (0.60 x V_{CC2}).
 - Possibility to disable the horizontal output pulse through the bus (force a high level on HOUT).
 - XRAY protection.
 - Horizontal position adjustment controlled by bus.
 - Bus controlled output voltage to adjust the vertical amplitude; this voltage permits to adjust the slope of the vertical sawtooth generated by the external frame booster.
 - Bus controlled vertical position ; the high level of the vertical pulse permits to adjust the vertical position.
 - Bus controlled 4/3-16/9 selection : the low level of the vertical pulse is 0.1V when 16/9 is selected, 2V when 4/3 is selected.
 - Combined flyback input and sandcastle output (Pin 37). Two thresholds on LFB/SCO Pin : The lowest threshold (0.7V) permits to extract the line blanking pulse; the highest threshold (2V) permits to extract the line pulse for PLL2. The sandcastle signal at Pin 37 is used to control the external baseband chroma delay line.

FUNCTIONAL DESCRIPTION (continued)**2 - FILTERS**

- Integrated trap filter :

$$Q = \frac{1}{\frac{f_0}{f_{-3dB}} - \frac{f_{-3dB}}{f_0}} \quad Q = 2.5 \text{ at sharp. min}$$

Center frequency : 4.43MHz,
3.58MHz for PAL, NTSC

- Integrated chroma bandpass : Q = 3.5
Center frequency : 4.43MHz, 3.58MHz
- Integrated delay line : Bandwidth = 8MHz
- Integrated low pass filter for deflection part.
- All filters are tuned with a reference phase locked loop. The PLL consists of a lowpass filter, a phase comparator, a loop filter (with an external capacitor). The reference signal is the continuous carrier wave from the VCO (4.43MHz or 3.58MHz). The PLL adjusts the center frequency of the lowpass so that it is equal to the reference signal. The tuning voltage of the PLL is used to adjust all other filters.

3 - VIDEO CIRCUIT

- 1 RGB input : fixed gain on RGB (OSD and external).
- Oversize blanking capability on FB(OSD)(Pin15) input. The RGB outputs will be blanked when the voltage on Pin 15 will exceed the second threshold at 2V (blanking threshold) : the whole field is blanked but not the inserted cut-off pulses. The OSD insertion threshold is 0.7V.

- Automatic cut-off current loop : 2V cut-off range. Sequential cut-off current measurement during the three lines after the frame blanking signal. Leakage current measurement during the frame blanking, memorization on an internal capacitor.
- Possibility to force through the bus the inserted cut-off pulses on lines 23/24/25(CCIR) in 50Hz and 60Hz mode. This will increase frame blanking time in 60Hz mode.
- Warm up detector.
- Beam current limiter DC voltage input. The beam current limiter control voltage will act on contrast first, then the brightness will be decreased when contrast attenuation reaches -5dB.
- Bus control of the red, green and blue channel gain (White point adjustment)
- Bus control of the red and green DC levels (black point adjustment)
- PAL matrix, specific NTSC matrix when demodulation angles are (0°, 104°).
- Switch-off of the trap filter in SVHS mode.
- Bus controlled contrast on luminance (20dB range)
- Bus controlled saturation (50dB range)
- Bus controlled brightness : 40% range at maximum contrast.
- Bus controlled sharpness (peaking).
- Noise coring function on sharpness. Can be disabled through the bus
- Bus controlled blue screen feature.
- Black stretcher. Can be disabled through the bus.

FUNCTIONAL DESCRIPTION (continued)**4 - CHROMA CIRCUIT****4.1 - PAL/NTSC Decoders**

- SVHS inputs ; bus controlled SVHS mode.
- 30dB range ACC
- Use of an external base band delay line (STV2180 recommended)
- Automatic standard identification, with possibility to force the standard through the bus.
- ACC done by peak detector on synchronous demodulation of the burst
- ACC overload.
- Fully integrated killer functions.
- VCO using two standard crystals : 4.43MHz and 3.58MHz. One crystal is internally selected depending on the standard selection.
- 3 crystals application capability : one crystal on Pin XTAL1 (4.43MHz or 3.58MHz), two crystals on Pin XTAL 2 (3.58MHz only) which can be selected by Pin 9 out signal.

XTAL SPECIFICATION :

Frequency	Motional Capacity
4.433619MHz (PAL)	13fF \pm 3fF
3.579545MHz (NTSC M)	11fF \pm 3fF
3.575611MHz (PAL M)	9fF \pm 1fF
3.582056MHz (PAL N)	10fF \pm 2fF

Vibration mode : Fundamental, series resonance (no serial capacitor)

Resonance resistance : < 70 Ω

Shunt capacitance : < 7pF

Spurious response : No resonance at $3*f_0 \pm 3kHz$

- 0° and $\pm 90^\circ$ demodulation angles for PAL
- (0°, 90°) or (0°, 104°) = demodulation angles for NTSC. The selection of 90° or 104° is made through the bus.
- Bus control Hue adjustment in NTSC mode.
- NTSC Automatic Flesh control. Bus controlled disable. Two automatic flesh control charac-

teristics : the first one with $\pm 20^\circ$ correction and a total action range of $\pm 90^\circ$, the second one with $\pm 10^\circ$ maximum correction and a total action range of $\pm 60^\circ$. The selection of the flesh characteristic is bus controlled.

- Switchable Chroma demodulator gain (+6dB) for NTSC only application, when no external chroma delay line is used.

4.2 - Standard Identification

- 3 identification sequences : XTAL1 (crystal on Pin 3), XTAL2-1 (first crystal on Pin 2), XTAL2-2 (second crystal on Pin 2). Parallel identification of PAL and NTSC.
- Blanking of the (R-Y) and (B-Y) outputs during color search mode.

5 - OTHER FUNCTIONS : IF CONTROLS**5.1 - Volume Control and Mute**

The volume control voltage range on Pin 10 is from 0.5V to 5V. A low voltage on Pin 10 (below 0.2V) will mute the FM demodulator of the IF circuit STV8223. It will put the volume at the minimum level and thus there will be no sound either in TV mode or External (AV) mode.

The volume control voltage and the mute level are controlled by the bus.

5.2 - TV/External Mode Selection

The selection of the TV/External (AV) mode is controlled by the bus. The selection is converted in two voltages on Pin 11.

The lowest voltage selects the TV mode.

The highest voltage (open collector output with internal pull-up resistor to V_{CC}) selects the External (AV) mode.

I²C BUS SPECIFICATION

General Comments Slave Address : 8A (HEX) (1000101X)

WRITE MODE DATA FORMAT

Slave Address	Register Address	Data
1000 1010 (8A)	XXXX SSSS (from 00 to 11HEX)	XXSS SSSS (6 significant bits Max.)

The not used bits in data byte must be put to "0"

READ MODE DATA FORMAT

Slave Address	Data
1000 1011 (8B)	SSSS SSSS (8 significant bits)

MSB on the left, LSB on the Right.

MSB

LSB

X	X	X	X	X	X	X	X
---	---	---	---	---	---	---	---

X : not significant bit - S : significant bit

Input Signals (Write Mode)

VIDEO

Address Dec (HEX)	Description	Data (Bits)	Comments
0 (00)	Contrast	5	XXX0 0000 = -20dB XXX1 1111 = 0dB
0 (00)	Not used	1	XXSX XXXX 0 = default value
1 (01)	Saturation	6	XX00 0000 = -44dB XX11 1111 = +6dB
2 (02)	Brightness	5	XXX0 0000 = -20% XXX1 1111 = +20%
2 (02)	RGB Outputs Blanking	1	XXSX XXXX 0 = Normal mode 1 = Blanking active
3 (03)	Red Drive Adjust (white point red adjust)	6	XX00 0000 = -6dB XX11 1111 = 0dB
4 (04)	Red Cut-off Adjust	6	XX00 0000 = +150mV XX11 1111 = -150mV
5 (05)	Green Drive Adjust (white point green adjust)	6	XX00 0000 = -6dB XX11 1111 = 0dB
6 (06)	Green Cut-off Adjust	6	XX00 0000 = +150mV XX11 1111 = -150mV
7 (07)	Blue Drive Adjust (white point blue adjust)	6	XX00 0000 = -6dB XX11 1111 = 0dB
8 (08)	Sharpness	3	XXXX X000 = Peaking Min. XXXX X111 = Peaking Max.
8 (08)	Blue Screen	1	XXXX SXXX 0 = blue screen disable 1 = blue screen enable
8 (08)	Third Crystal Selection (This bit is not significant in automatic color standard mode - data = 06Hex in register 0AHex)	1	XXXX XXXX 0 = low level on Pin 9 1 = high level on Pin 9
8 (08)	Black Stretch Enable	1	XXSX XXXX 0 = disable 1 = enable
16 (10)	Coring on Sharpness	1	XXXX SXXX 0 = Coring on 1 = Coring off
16 (10)	Cut-off Pulse Position	1	XXXX XXXX 0 = lines 23/24/25 in 50z lines 18/18/20 in 60Hz 1 = lines 23/24/25 both in 50Hz and 60Hz

I²C BUS SPECIFICATION (continued)**Input Signals** (Write Mode) (continued)

CHROMA

Address Dec (HEX)	Description	Data (Bits)	Comments
9 (09)	Hue	6	XX00 0000 = -45° XX11 1111 = +45°
10 (0A)	Standard Selection	4	XXXX SSSS 0000 = PAL/XTAL1 (4.43MHz) 0001 = PAL/XTAL2 (3.58MHz) 0010 = NTSC/XTAL1/90° 0011 = NTSC/XTAL2/90° 1010 = NTSC/XTAL1/104° 1011 = NTSC/XTAL2/104° 011X = Auto/90° 111X = Auto/104° 0100 = Not allowed 0101 = Not allowed 1000 = Not allowed 1001 = Not allowed 1100 = Not allowed 1101 = Not allowed
10 (0A)	SVHS Selection	1	XXXS XXXX 0 = No SVHS (CVBS mode) 1 = SVHS mode
10 (0A)	XTAL1 (Pin 3) Indication	1	XXSX XXX 0 = 4.43MHz Crystal on Pin 3 1 = 3.58MHz Crystal on Pin 3
14 (0E)	Chroma Demodulation Gain	1	XXXS XXXX 0 = 0dB 1 = +6dB
14 (0E)	Flesh Control	1	XXSX XXXX 0 = Flesh control disable 1 = Flesh control enable
16 (10)	Flesh Characteristics	1	XXSX XXXX 0 = Narrow characteristic ($\pm 12^\circ$) 1 = Wide characteristic ($\pm 20^\circ$)

DEFLECTION

Address Dec (HEX)	Description	Data (Bits)	Comments
11 (0B)	Horizontal Shift	6	XX00 0000 = -2.5 μ s XX11 1111 = +2.5 μ s
12 (0C)	Vertical Amplitude	6	XX00 0000 = 1.2V XX11 1111 = 6.2V
13 (0D)	Vertical Position	3	XXXX X000 = 3.8V XXXX X111 = 6.3V
13 (0D)	50/60Hz Selection	2	XXXS SXXX 00 = Auto 01 = 60Hz 10 = 50Hz 11 = Auto
13 (0D)	Horizontal Output (HOUT) Safety	1	XXSX XXXX 0 = Normal mode 1 = HOUT disabled (high level)
14 (0E)	PLL1 Time Constant	2	XXXX XXSS 00 = Normal mode (Auto) 01 = Short time constant 10 = Very long time constant 11 = PLL1 inhibition (open loop)
14 (0E)	Interlace	1	XXXX XSXX 0 = Interlace 1 = DE-Interlace
14 (0E)	4/3 16/9 Selection	1	XXXX SXXX 0 = 4/3 (V _{OUT-Low} = 2V) 1 = 16/9 (V _{OUT-Low} = 0.1V)

STV2216

I²C BUS SPECIFICATION (continued)

Input Signals (Write Mode) (continued)

OTHERS

Address Dec (HEX)	Description	Data (Bits)	Comments
15 (0F)	Volume	6	XX00 0000 = 0.5V XX11 1111 = 5V
16 (10)	Mute	1	XXXX XXS 0 = Mute not active 1 = Mute active
16 (10)	AV Switch Selection	2	XXXX XSSX 00 = TV mode 01 = not allowed 10 = not allowed 11 = External (AV) mode
17 (11)	Only for Test	6	XXSS SSSS 00 0000 = Test mode not active

Output Signals (Read Mode)

READ REGISTER

Description	Data (Bits)	Comments
Field Frequency	1	XXXX XXS 1 = 50Hz 0 = 60Hz
Video Identification	1	XXXX XXS 1 = No Identification 0 = Video Identification
SVHS Status	1	XXXX XSX 1 = No SVHS 0 = SVHS
Standard Status	3	XXSS SXXX 111 = PAL/XTAL1 (4.43MHz) 110 = NTSC/XTAL1 101 = not to be used 011 = PAL/XTAL2 (3.58MHz) 010 = NTSC/XTAL2 X00 = Color off
Circuit Identification	2	00XX XXXX 11 = STV2118A/2116/2112 10 = STV2116A 01 = STV2112A 00 = STV2216

Bus Register Initial Conditions (Not used bits are preset to "0")

Address Dec (HEX)	Data Initial Value	Comments
0 (00)	XX01 0000	Mid. contrast ; Not used
1 (01)	XX10 0000	Mid. saturation
2 (02)	XX01 0000	Mid. brightness ; Blanking : normal mode
3 (03)	XX10 0000	Mid. RED drive adjust
4 (04)	XX10 0000	Mid. RED cut-off adjust
5 (05)	XX10 0000	Mid. GREEN drive adjust
6 (06)	XX10 0000	Mid. GREEN cut-off adjust
7 (07)	XX10 0000	Mid. BLUE drive adjust
8 (08)	XX10 0100	Mid. sharpness ; Blue screen not active ; External crystal selection in auto mode ; Black stretch on
9 (09)	XX10 0000	Mid. hue
10 (0A)	XX00 0110	Auto search color standard ; no SVHS ; XTAL1 = 4.43MHz
11 (0B)	XX10 0000	Mid. horizontal shift
12 (0C)	XX10 0000	Mid. vertical amplitude
13 (0D)	XX00 0100	Mid. vertical position ; Auto search field frequency ; HOUT : normal mode
14 (0E)	XX00 0000	PLL1 time constant : normal mode ; Interlace ; 4/3 selection ; chroma gain = +0dB ; no flesh
15 (0F)	XX10 0000	Mid. volume
16 (10)	XX00 0000	Mute not active ; INT/FM IF mode ; coring on ; Cut-off pulses on lines 23/24/25 in 50Hz or lines 18/19/20 in 60Hz ; narrow flesh characteristic
17 (11)	XX00 0000	Test mode not active

ABSOLUTE MAXIMUM RATINGS

Symbol	Parameter	Value	Unit
V _{CC}	Supply Voltage (Pins 22-42) ($V_{CC1(22)} \leq V_{CC2(42)}$)	12	V
T _{oper}	Operating Temperature	0, +70	°C
T _{stg}	Storage Temperature	-55, +150	°C

2216-01.TBL

THERMAL DATA

Symbol	Parameter	Value	Unit
R _{th(j-a)}	Junction-ambient Thermal Resistance (P _D = 1.3W) Typ.	40	°C/W

2216-02.TBL

ELECTRICAL CHARACTERISTICS (V_{CC} = 9V, T_{amb} = 25°C, unless otherwise specified)

Symbol	Parameter	Test Condition s	Min.	Typ.	Max.	Unit
--------	-----------	------------------	------	------	------	------

SUPPLY

V _{CC1}	Video Supply Voltage ($V_{CC1} \leq V_{CC2}$)		8.1	9	9.9	V
V _{CC2}	Chroma & Scanning & Bus Supply Voltage		8.1	9	9.9	V
I _{CC1}	V _{CC1} Current Consumption		55	75	95	mA
I _{CC2}	V _{CC2} Current Consumption		40	60	80	mA
P _{tot}	Power Total Dissipation			1215	1600	mW

LUMINANCE /CVBS INPUT (Pin 20)

DC ₂₀	DC Operating Voltage	No input signal	3.55	3.7	3.95	V
V _{20PP}	CVBS or Y Input Voltage			1	1.41	V _{PP}
GY	Luma Gain	Contrast Max., Drive Max.		4.1		-
CTRY	Luma Contrast Range		18	20	22	dB
-I ₂₀	Negative Clamping Current	During sync. pulse	-20	-25	-35	μA
I ₂₀	Clamping Current		3	5	10	μA

COMBINED CHROMINANCE AND SVHS SELECTION INPUT (Pin 23)

V ₂₃	Chrominance Input Voltage	Burst Amplitude, 100/75 colour bar		0.3		V _{PP}
V _{CLIP23}	Input Amplitude before Clipping		1.0			V _{PP}
V _{DC23}	DC Voltage	SVHS mode	1.4	1.6	1.8	V
V _{TH23}	SVHS Threshold Voltage		0.5	0.7		V
I _{low23}	Input Current	0V at Pin 23	70	120	170	μA
V _{min23}	Minimum Burst Signal Amplitude within the ACC Control Range			30		mV _{PP}
G _{ACC}	ACC Control Range	Change of Burst over whole ACC control range < 2dB		30		dB
Killer	Colour Killer on Threshold Colour killer off hysteresis	Burst amplitude on Pin 20 or Pin 23, S/N > 40dB PAL Mode NTSC Mode PAL & NTSC Mode		4 1 +3		mV _{PP} mV _{PP} dB
RIN	Chrominance Input Resistance			8		kΩ

RGB INPUTS (Pins 12-13-14)

V _{CLAMP}	Clamp Level	Contrast Max., Drive Nom.	1.5	1.85	2.2	V
V _{RGB}	RGB Input Voltage	B to W		0.7	1	V _{PP}
G _{RGB}	RGB Gain	Contrast Max., Drive Max.		4.0		-
ΔBlack	Difference of Black Level of Internal and External signals at the Outputs				200	mV
I _{RGB}	Clamping Current			100		μA

2216-03.TBL

ELECTRICAL CHARACTERISTICS ($V_{CC} = 9V$, $T_{amb} = 25^{\circ}C$, unless otherwise specified) (continued)

Symbol	Parameter	Test Conditions	Min.	Typ.	Max.	Unit
FAST BLANKING INPUT (Pin 15)						
$V_{THFB1-15}$	Insertion Threshold Voltage		0.5	0.7	0.85	V
$V_{THFB2-15}$	Blanking Threshold Voltage		1.6	2.0	2.4	V
T_{sw1-15}	Insertion Switching Delay			30		ns
T_{sw2-15}	Blanking Switching Delay			50		ns
I_{FB-15}	Input Current	0V at Pin 15			50	μA

BLACK STRETCH CONTROL (Pin 18) (Figure 7)

BS_{th1}	Black Expansion Start Point	Y/CVBS (Pin 20), 0.7V (B/W)		50		%
$BS_{Max.}$	Maximum Expansion referred to B/W	Y/CVBS (Pin 20), 0.7V (B/W)		-20		%
$BSV_{Max.-18}$ $BSV_{Min.-18}$	Black Stretch Control Voltage	Maximum black stretch No black stretch		5.2 5.9		V V
I100IRE	Discharging Current	Y = 100IRE		8		μA
I0IRE	Loading Current	Y = 0IRE		25		μA

CATHODE CURRENT INPUT (Pin 30)

V_{LEAK}	Leakage Current Reference Voltage			1.80	2.0	V
V_{Coff}	Cut-off Current Reference Voltage referred to Leakage Current Reference			250		mV
V_{SB}	Start Beam Current Detection Reference Voltage		2.1	2.3		V
I_{Low-30}	Source current		150	250		μA

AUTOMATIC CUT-OFF CAPACITORS (Pins 24-25-26)

$I_{24-25-26}$	Control Current		70	100	130	μA
----------------	-----------------	--	----	-----	-----	---------

BEAM CURRENT LIMITER VOLTAGE (Pin 31)

V_{TH1-31}	Contrast Attenuation Starting			6.0		V
V_{TH2-31}	Brightness Attenuation Starting			5.5		V
V_{TH3-31}	Contrast Attenuation Ending			5.0		V
CTR-BCL	Contrast Attenuation at $V_{31}=V_{TH3-31}$			14.0		dB
V_{TH4-31}	Brightness Attenuation Ending			4.5		V
BRIG-BCL	Brightness Attenuation at $V_{31}=V_{TH4-31}$		100			%
CLP_{31}	High Clamping Voltage		6.5			V

RGB OUTPUTS (Pins 27-28-29)

V_{BW}	Output Signal Amplitude (B to W)	0.7V B/W at Pin 20, Drive Max., Contrast Max., Brightness Typ., Saturation Typ.		2.85		V
$I_{S27-28-29}$	Output Sinking Current		1.5	2		mA
$V_{M27-28-29}$	Maximum Peak White Level			7.8		V
$V_{Black27-28-29}$	Blanking Level	No load	0.3	0.45	0.6	V
RCO	Cut-off Output Range		2	2.6		V
DCCO	Cut-off Adjustment Range	On Red and Green outputs Pins 29 and 28, Drive Max.		300		mV
DRIV	Drive Adjustment Range			7		dB
R BRIG	Brightness Range	Relative to B/W amplitude on R,G,B outputs at Contrast Max.	30	40	50	%

ELECTRICAL CHARACTERISTICS ($V_{CC} = 9V$, $T_{amb} = 25^{\circ}C$, unless otherwise specified) (continued)

Symbol	Parameter	Test Conditions	Min.	Typ.	Max.	Unit
RGB OUTPUTS (Pins 27-28-29) (continued)						
ΔV_{CTR}	Variation of Black Level with Contrast				100	mV
ΔV_{SAT}	Variation of Black Level with Saturation				50	mV
ΔV_{REL}	Relative Variation in Black Level between the three Channels - during Variation of Contrast(10dB) - during Variation of Brightness ($\pm 0.5V$) - during Variation of V_{CC} ($\pm 10\%$)	Drive Max.		5	TBD TBD	mV mV mV
ΔV_{Temp}	Black Level Thermal Drift			1		mV/ $^{\circ}C$
Track	Tracking between Luminance and Chrominance Signals	From Max. contrast (0dB) to -10dB contrast			2	dB
Bwidth	Bandwith of Output Signals at -3dB - CVBS Input (no SVHS) - CVBS Input (no SVHS) - Y Input SVHS Mode - RGB Inputs	$f_{OSC} = 3.58MHz$, Sharp Typ. $f_{OSC} = 4.43MHz$, Sharp Typ. No trap Filter, Sharp Typ.	2.5 2.7 6 8	3.1 3.7 8		MHz MHz MHz MHz
S/N	Signal to Noise Ratio of Output (V_{PP}/V_{RMS}) Signal on Y/CVBS Input	No signal on R-Y, B-Y inputs Contrast Max., Drive Max., Saturation Typ., Sharp Typ., Bandwidth 5MHz, SVHS mode		50		dB
Res	Residual Frequency at f_{OSC} at 2 f_{OSC} and Higher Harmonics	PAL PAL		25 10	50	mV $_{PP}$ mV $_{PP}$

FILTERS TUNING VOLTAGE

V_{TUN1}	Tuning Voltage Range (Pin 8)			3.2 to 4.8		V
------------	------------------------------	--	--	---------------	--	---

EXTERNAL CRYSTAL SELECTION (Pin 9)

V_{LOW9}	Low Level Voltage	No load		0.02	0.1	V
I_{LOW9}	Low Level Current	Low level voltage on Pin 9	70	100		μA
V_{HIGH9}	High Level Voltage	No load	3.0	3.5	4.0	V
I_{HIGH9}	High Level Current	High level voltage on Pin 9	70	100		μA

Y DELAY LINE

t_{d1p} t_{d2p}	Delay Time PAL 4.43MHz	SVHS mode CVBS mode	330 380	370 420	410 460	ns ns
t_{d1n} t_{d2n}	Delay Time NTSC 3.58MHz	SVHS mode CVBS mode	370 435	410 475	450 515	ns ns

SHARPNESS CIRCUIT

f_{Sharp}	Center Frequency	SVHS mode		2.5		MHz
G_{Sharp}	Gain Variation from Min. to Max. Sharp	at f_{Sharp}		6		dB
Overshoot	Amplitude Variation compared to B/W	2T pulse, Sharp Max., CVBS		150		%
Pre-shoot	Amplitude Variation compared to B/W	2T pulse, Sharp Max., CVBS		-25		%
After-shoot	Amplitude Variation compared to B/W	2T pulse, Sharp Max., CVBS		-60		%
Coring	Coring Range compared to B/W			10		%

Y TRAP FILTER

f_{Trap}	Trap Frequency	PAL/NTSC	-0.2	f_{OSC}	+0.2	MHz
Q_{Trap}	Trap Quality Factor ($Q=1/(f_0/f-3dB - f-3dB/f_0)$)	Sharpness Min.		2.5		-
CR _{ejPN}	Color Subcarrier Rejection	PAL mode, Sharpness Min. NTSC mode, Sharpness Min.	18 15			dB dB

2216-05.TBL

ELECTRICAL CHARACTERISTICS ($V_{CC} = 9V$, $T_{amb} = 25^{\circ}C$, unless otherwise specified) (continued)

Symbol	Parameter	Test Conditions	Min.	Typ.	Max.	Unit
CHROMINANCE BANDPASS						
f_C	Center Frequency		-0.2	f_{osc}	+0.4	MHz
Q_{BP}	Bandpass Quality Factor		3.0	3.8	4.7	-
ACC CAPACITOR (Pin 5)						
I_{C5}	Charging Current	During burst gate window		250		μA
I_{L5}	Leakage Current			0.2	1	μA
ACC OVERLOAD CAPACITOR (Pin 17)						
I_{C17}	Charging Current			12.5		μA
I_{L17}	Leakage Current			0.2	1	μA
V_{th-17}	Chroma Regulation Level	referred to nom. chroma level		+3		dB
CHROMA PLL (Pins 2-3)						
CR_{2-3}	Catching Range	$Q = 4.43MHz$ (Pin 3) $Q = 3.58MHz$ (Pin 2)		± 600 ± 500		Hz Hz
PLL LOOP FILTER (Pin 4)						
I_{C4}	Control Current	During burst gate window		400		μA
I_{L4}	Leakage Current				5	μA
HUE CONTROL (in NTSC mode only)						
CR_{HUE}	HUE Control Range		± 25	± 45	± 65	Deg
COLOR DIFFERENCE OUTPUT SIGNALS (Pins 40-41)						
PAL/NTSC DEMODULATORS						
V_{P40}	R-Y Output signal Amplitude (Pin 40)	RED-BLUE axes = 90° 100/75 colour bar - PAL mode	0.40	0.52	0.64	V_{PP}
V_{P41}	B-Y Output Signal Amplitude (Pin 41)	RED-BLUE axes = 90° 100/75 colour bar - PAL mode	0.48	0.60	0.75	V_{PP}
G_{PAL}	Gain Ratio of both Demodulators (B-Y)/(R-Y)	RED-BLUE axes = 90° 100/75 colour bar	1.0	1.15	1.30	-
G_{NTSC}	Gain Ratio of both Demodulators (B-Y)/(R-Y)	RED-BLUE axes = 104° 100/75 colour bar	1.0	1.23	1.50	-
V_{PNDC}	Output Voltage when colour killed		5.1	5.6	6.1	V
PAL/NTSC (90°) MATRIX						
G/R	(G-Y)/(R-Y)		-0.62	-0.51	-0.4	-
G/B	(G-Y)/(B-Y)		-0.30	-0.19	-0.15	-
NTSC (104°) MATRIX						
NG/R	(G-Y)/(R-Y)			-0.29		-
NG/B	(G-Y)/(B-Y)			-0.22		-
AUTOMATIC FLESH CONTROL (see Figure 8)						
$Flesh_{Nom.}$	Nominal Flesh Tint Phase			118		Deg
$Flesh_{Dv1}$	Phase Shift when Auto Flesh on	At $Flesh_{Nom.}$		0		Deg
$Flesh_{Dev2A}$ $Flesh_{Dev2B}$	Maximum Phase Correction	Register 10Hex D5 = 0 Register 10Hex D5 = 1		± 12 ± 20		Deg Deg
$Flesh_{Max.A}$ $Flesh_{Max.B}$	Chroma Input Phase at Max. Correction	ref. to $Flesh_{Nom.}$ R10D5 = 0 ref. to $Flesh_{Nom.}$ R10D5 = 1		± 30 ± 45		Deg Deg
$Flesh_{RangeA}$ $Flesh_{RangeB}$	Auto Flesh Control Range	ref. to $Flesh_{Nom.}$ R10D5 = 0 ref. to $Flesh_{Nom.}$ R10D5 = 1		± 60 ± 90		Deg Deg

ELECTRICAL CHARACTERISTICS ($V_{CC} = 9V$, $T_{amb} = 25^{\circ}C$, unless otherwise specified) (continued)

Symbol	Parameter	Test Conditions	Min.	Typ.	Max.	Unit
--------	-----------	-----------------	------	------	------	------

SATURATION CONTROL

SAT _{Max.}	Maximum Saturation Control (3F)	1V _{PP} CVBS on Pin 20	+4.5	+6.0	+7.5	dB
SAT _{Nom.}	Nominal Saturation Control (20)	1V _{PP} CVBS on Pin 20		0		dB
SAT _{Min.}	Minimum Saturation Control(00)	1V _{PP} CVBS on Pin 20		-44		dB

COLOUR DIFFERENCE INPUT SIGNALS (Pins 38-39)

DCRYI	DC Voltage Pin 39	No colour	2.6	2.8	3.0	V
DCBYI	DC Voltage Pin 38	No colour	2.6	2.8	3.0	V
VRyI	Input Signal Amplitude Pin 39	100/75 color bar		1.05		V _{PP}
VB _Y I	Input Signal Amplitude Pin 38	100/75 color bar		1.33		V _{PP}
I _{CL38-39}	Clamping Current	During burst key	100	180	260	μA

SYNC. SEPARATOR

V _{Sync}	Sync. Pulse Amplitude	On Pin 20	50	300		mV
-------------------	-----------------------	-----------	----	-----	--	----

HORIZONTAL OSCILLATOR

f _{H50}	Frequency after Divider	50Hz input signal		15625		Hz
f _{H60}	Frequency after Divider	60Hz input signal		15734		Hz
f _{Rang}	Frequency Control Range	Low Frequency High Frequency		14925 16325		Hz Hz
f _{free}	Free Running Frequency when PLL1 open	Value 03hex in register 0Ehex	15000	15800		Hz

FIRST LOOP FILTER (Pin 33)

I _{LOW-33}	Long Time Constant Output Current		0.13	0.17	0.20	mA
I _{HIGH}	Short Time Constant Output Current		0.35	0.45	0.55	mA
I _{VLOW}	Very Long Time Constant		0.02	0.03	0.05	mA

SECOND CONTROL LOOP

CRQ ₂	Control Range from Start of Horizontal Output to Flyback	Horizontal position centered		2 to 14		μs
t _{shift}	Horizontal Shift Range		4			μs

LINE FLYBACK INPUT/SANDCASTLE OUTPUT (Pin 37)

V _{SCO}	Output Voltage during Burst Key		4.0	5.0		V
V _{CL37}	Clamped Input Voltage during Flyback			2.5	3.1	V
t _{WBG}	Burst Key Pulse Width		3.5	3.8	4.0	μs
t _{dBG}	Delay of Start of Burst Key to Start of Sync.			5.2		μs
V _{TH1-37}	Blanking Threshold Voltage		0.5	0.7	0.9	V
V _{TH2-37}	PLL2 Threshold Voltage referred to Line Level V _{CL37}	PLL2V _{TH} /V _{CL37}		80		%
I ₃₇	Input Current	During flyback pulse	0.1		1	mA

2216-07 TBL

ELECTRICAL CHARACTERISTICS ($V_{CC} = 9V$, $T_{amb} = 25^{\circ}C$ unless otherwise specified) (continued)

Symbol	Parameter	Test Conditions	Min.	Typ.	Max.	Unit
HORIZONTAL OUTPUT (Pin 36)						
T_{W36}	Output Pulse Width	Normal operation	26	28	30	μs
V_{Low36}	Voltage Output Low	R pull-up = 1k Ω		1.1		V
$V_{CC\ Start}$	$V_{CC\ Start}$ Level	Voltage on Pin 42		6.7	7.2	V
$V_{CC\ Stop}$	$V_{CC\ Stop}$ Level : hysteresis	Voltage on Pin 42, $V_{CCstart} - V_{CCstop}$		0.60		V
$I_{36\ Max.}$	Maximum Allowed Output Current				10	mA
$V_{36\ Max.}$	Maximum Allowed Output Voltage (open collector)				12	V
T_{ss}	Output Pulse Duty Cycle in soft-start mode (Thigh/(Thigh + Tlow))	$V_{CC2} = 9V$, $V_{CC1} < 6.8V$ (V_{CC1} rising)		78		%

VERTICAL OUTPUT (Pin 35)

T_{W35}	Output Pulse Width			10.5		Lines
V_{Low35}	Low Level Output Voltage 4/3 Low Level Output Voltage 16/9	XXXX0XXX (bin) in Reg. 0Ehex XXXX1XXX (bin) in Reg. 0Ehex	1.5	2 0.1	2.5 0.5	V V
FR35	Locking Range		248		352	Lines
f_{FR-50}	Free Frequency (no Video Signal)	50Hz or Auto Mode		314		Lines
f_{FR-60}	Free Frequency (no Video Signal)	60Hz Mode		264		Lines
V_{HIGH35}	High Level Range (vertical position control)	XXXXX000(bin) in Reg. 0Dhex XXXXX111(bin) in Reg. 0Dhex	3.45 5.6	3.8 6.3	4.2 7.0	V V
I_{sink}	Output Sinking Current	4/3 16/9		0.2 0.5		mA mA

VERTICAL AMPLITUDE CONTROL (Pin 34)

V_{34R}	Output Voltage Range	XX000000(bin) in Reg. 0Chex XX111111(bin) in Reg. 0Chex	1.0 5.4	1.2 6.2	1.5 6.9	V V
-----------	----------------------	--	------------	------------	------------	--------

XRAY INPUT (Pin 19)

V_{th19}	Protection Threshold Voltage	At Pin 19	1.15	1.3	1.45	V
$V_{Hold-19}$	Hold Voltage	At Pin 42			3	V

VOLUME CONTROL AND MUTE (Pin 10)

V_{R10}	Output Voltage Range (volume control)	XX000000(bin) in Reg. 0Fhex XX111111(bin) in Reg. 0Fhex	0.35 4.2	0.5 4.75	0.7 5.3	V V
MUT	Output Voltage when MUTE	XXXXXXXX1(bin) in Reg. 10hex		0.02	0.1	V

SWITCH SELECTION (Pin 11)

$V_{TV/NEG}$	Output Voltage in TV Mode	$V_{CC} = 9V$		0.1	0.7	V
$V_{Scart/Neg}$	Output Voltage in External Mode (open collector mode)	$V_{CC} = 9V$	7.88	9		V
$R_{TV/Neg}$	Output Resistance in TV Mode			200		Ω
$R_{Scart/Neg}$	Output Resistance in External Mode (pull-up resistor to V_{CC})			18		k Ω

I²C BUS INPUTS (Pins 6-7)

V_{TH6-7}	Threshold Voltage		1.5	2.25	3	V
C_{L6-7}	Capacitance of each Pin			5	10	pF
$I_{Leak6-7}$	Leakage Current	Write Mode, 0 level on SDA or SCL			50	μA

USER CONTROLS

Figure 1 : Contrast Control Curve

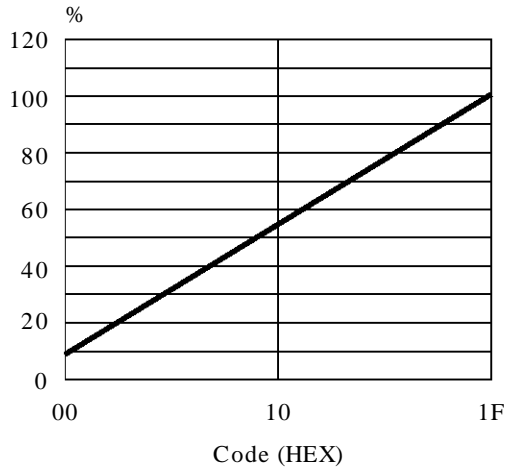

2216-03.EPS

Figure 2 : Saturation Control Curve

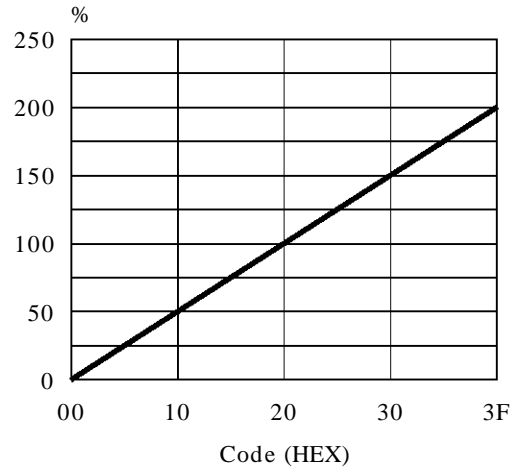

2216-04.EPS

Figure 3 : Brightness Control Curve

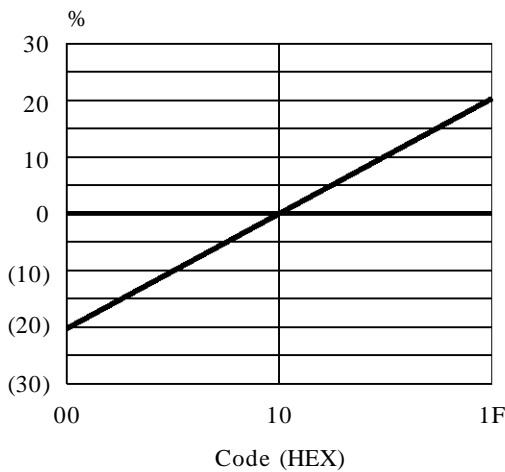

2216-05.EPS

Figure 4 : Hue Control Curve

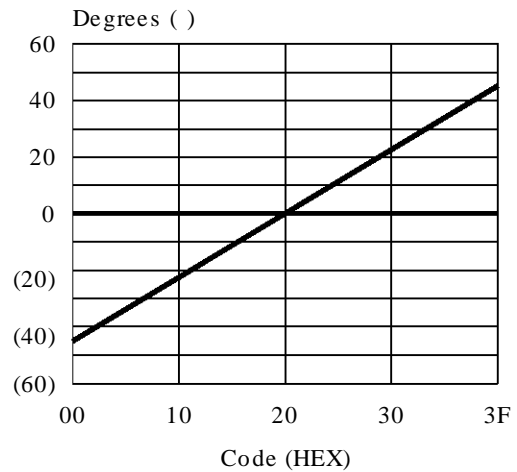

2216-06.EPS

Figure 5 : Peaking Control (2T overshoot)

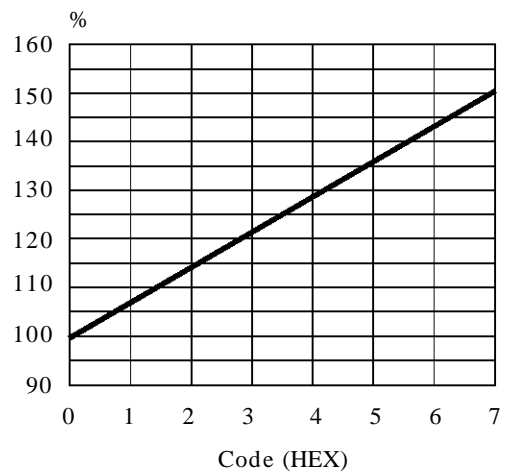

2216-07.EPS

Figure 6 : Volume Control Curve

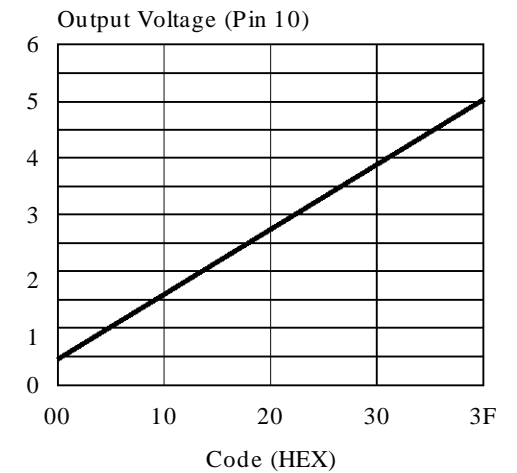

2216-08.EPS

SPECIAL FEATURES

Figure 7 : Black Stretch Control

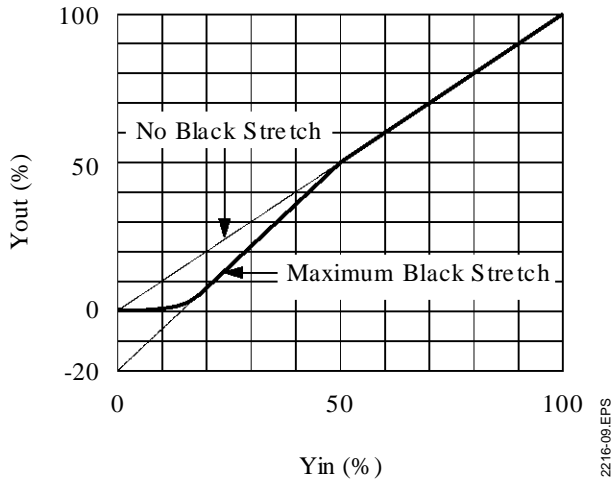

2216-09.EPS

Figure 8 : Automatic Flesh Tint Control

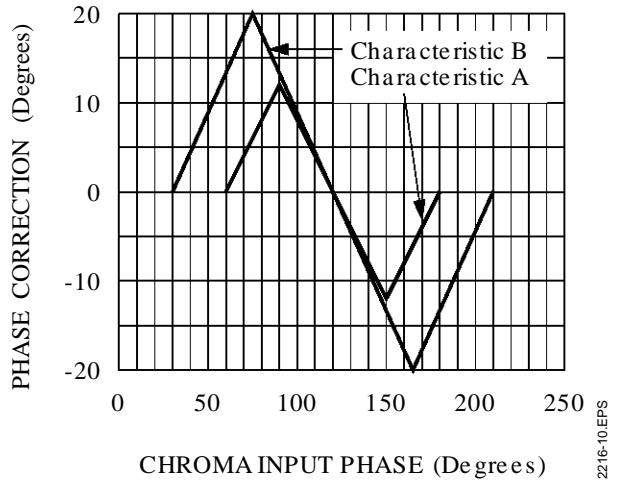

2216-10.EPS

INPUT/OUTPUT PIN CONFIGURATION

Figure 9 : Pins 2, 3 - CXTL1, CXTL2

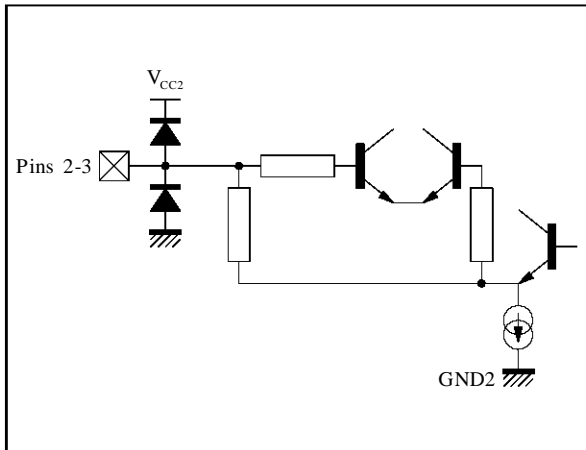

2216-11.EPS

Figure 10 : Pin 4 - CLPF

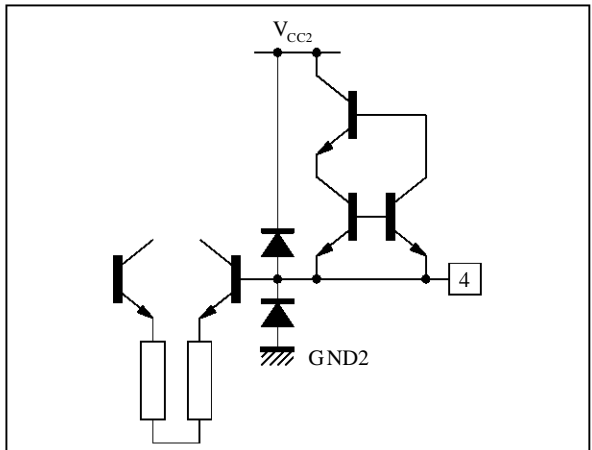

2216-12.EPS

Figure 11 : Pin 5 - ACC

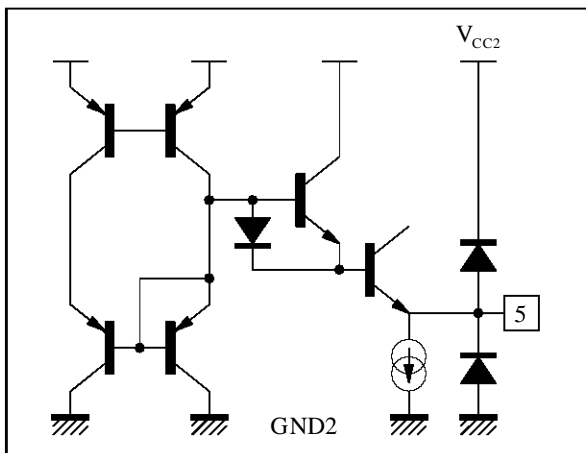

2216-13.EPS

Figure 12 : Pin 6 - SDA

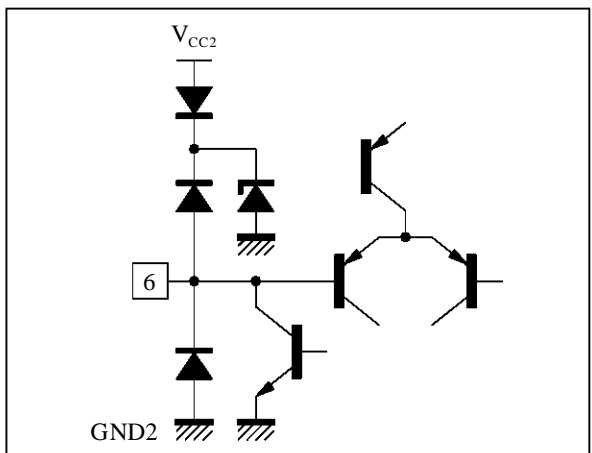

2216-14.EPS

INPUT/OUTPUT PIN CONFIGURATION (continued)

Figure 13 : Pin 7 - SCL

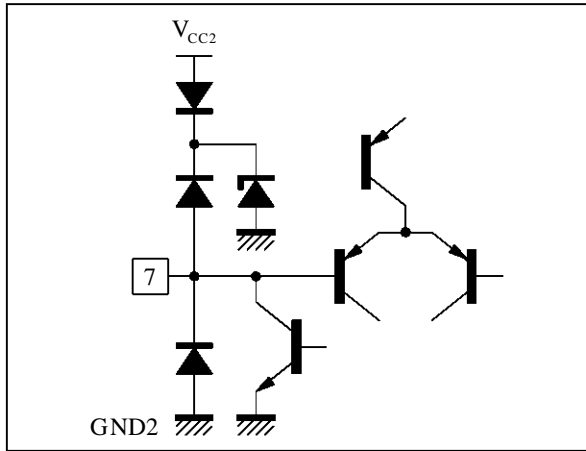

2216-15.EPS

Figure 14 : Pin 8 - FTUN1

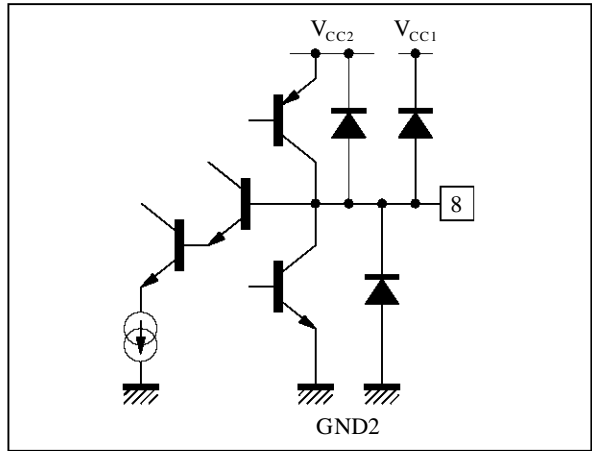

2216-16.EPS

Figure 15 : Pin 9 - CRYSTAL SWITCH

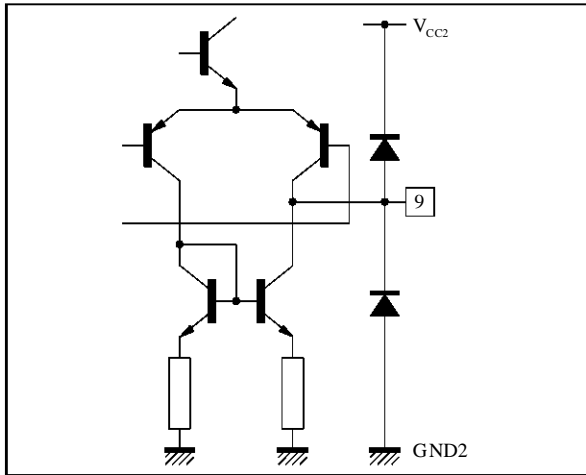

2216-17.EPS

Figure 16 : Pin 10 - Volume

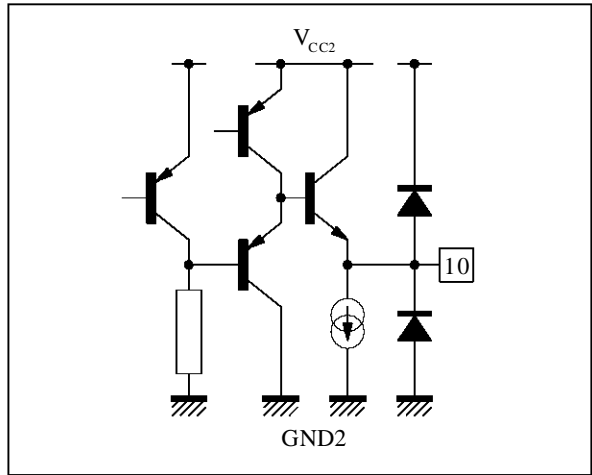

2216-18.EPS

Figure 17 : Pin 11 - SWI

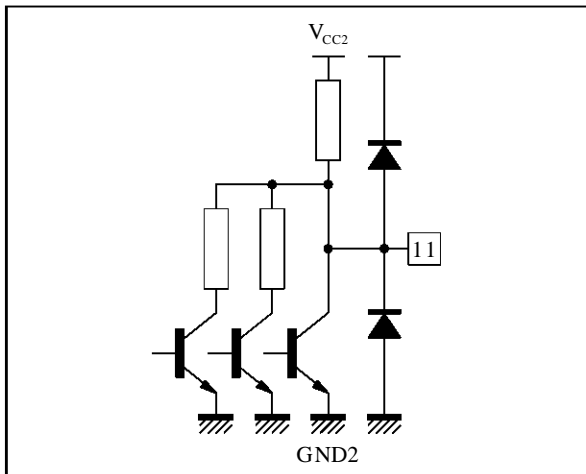

2216-19.EPS

Figure 18 : Pins 12,13,14 - RGB Inputs

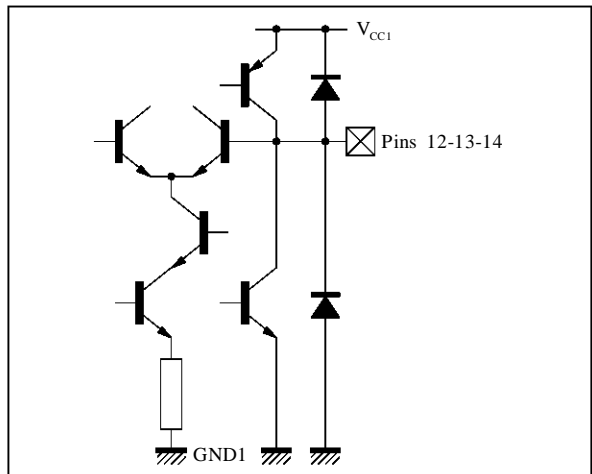

2216-20.EPS

INPUT/OUTPUT PIN CONFIGURATION (continued)

Figure 19 : Pin 15 - FBOSD

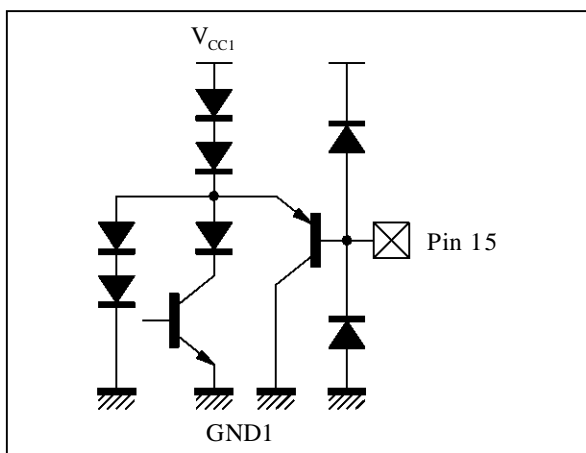

2216-21.EPS

Figure 20 : Pin 17 - ACC OVERLOAD

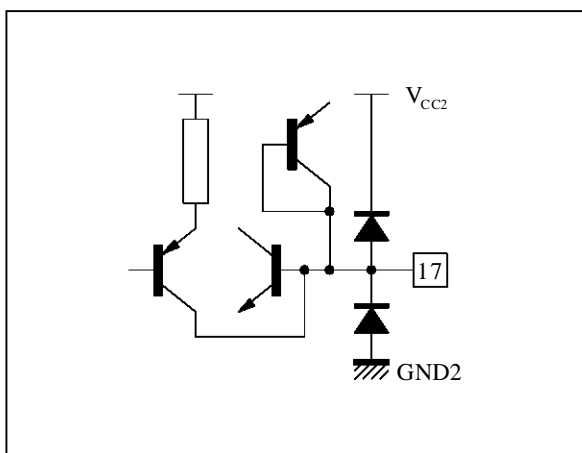

2216-22.EPS

Figure 21 : Pin 18 - Black Stretch Filter

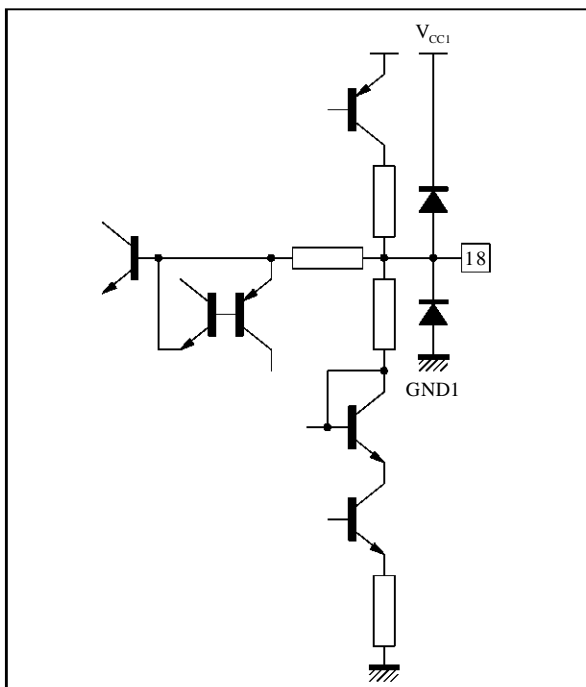

2216-23.EPS

Figure 22 : Pin 19 - XRAY Input

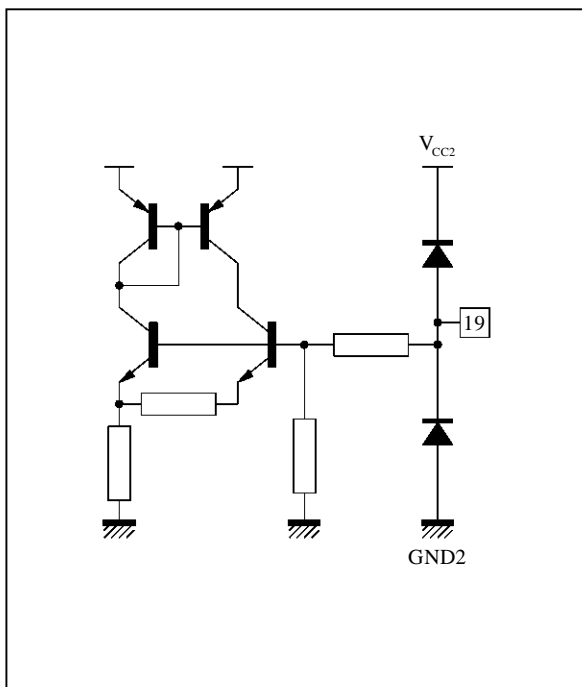

2216-24.EPS

INPUT/OUTPUT PIN CONFIGURATION (continued)

Figure 23 : Pin 20 - Y/CVBS

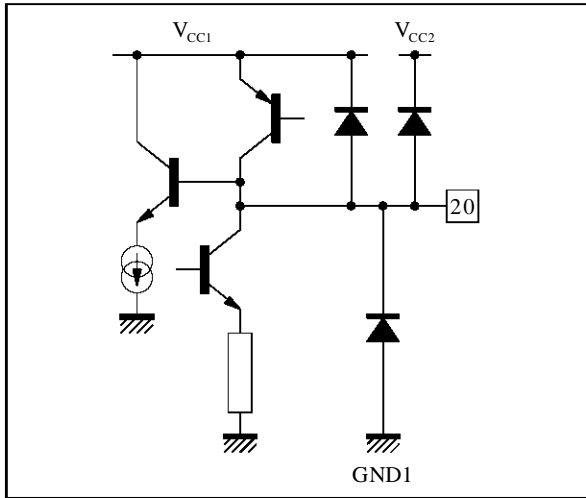

2216-25.EPS

Figure 24 : Pin 23 - CHR/SVHS

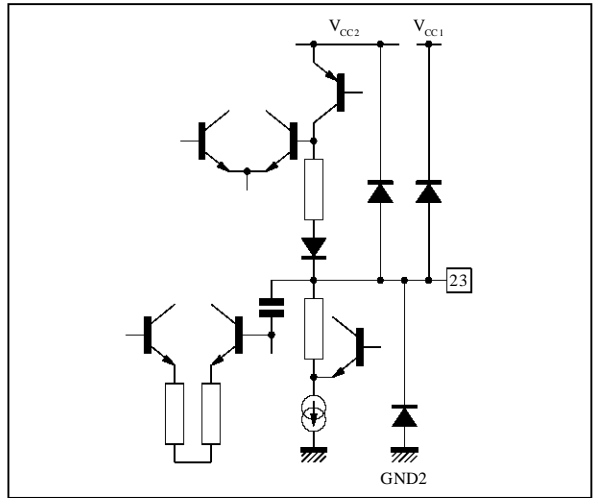

2216-26.EPS

Figure 25 : Pins 24, 25, 26 - CG, CR, CB

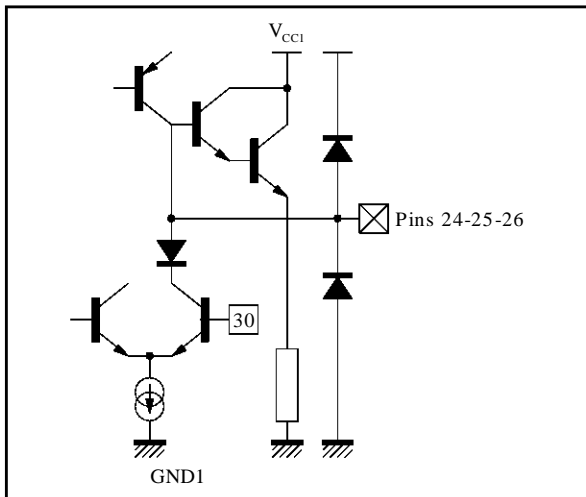

2216-27.EPS

Figure 26 : Pins 27, 28, 29 - BO, GO, RO

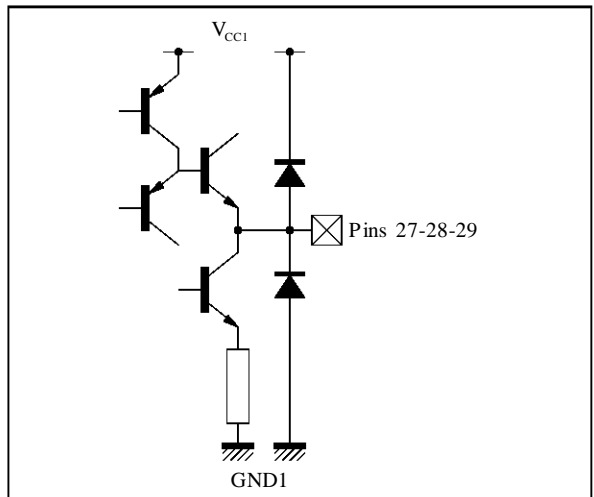

2216-28.EPS

Figure 27 : Pin 30 - ICAT

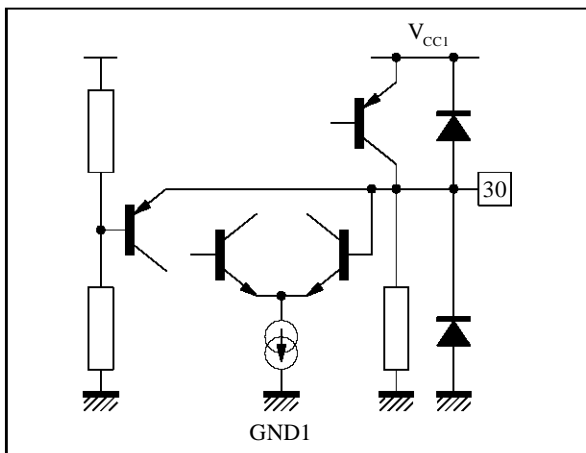

2216-29.EPS

Figure 28 : Pin 31 - BCL

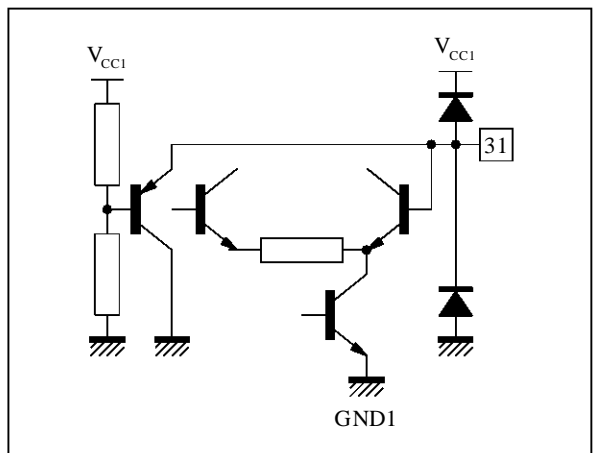

2216-30.EPS

INPUT/OUTPUT PIN CONFIGURATION (continued)

Figure 29 : Pin 32 - SXTL

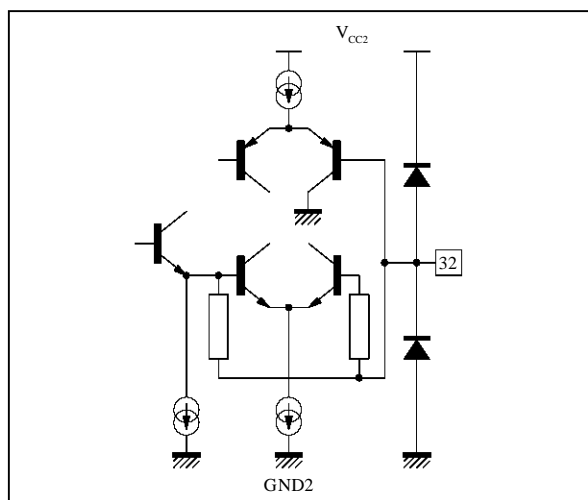

2216-31.EPS

Figure 30 : Pin 33 - SLPF

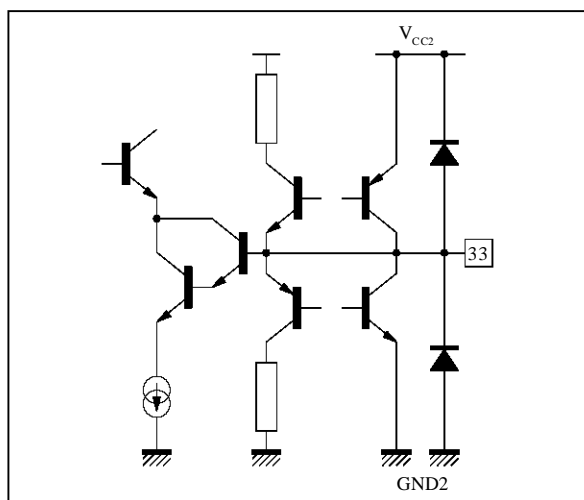

2216-32.EPS

Figure 31 : Pin 34 - VAMP

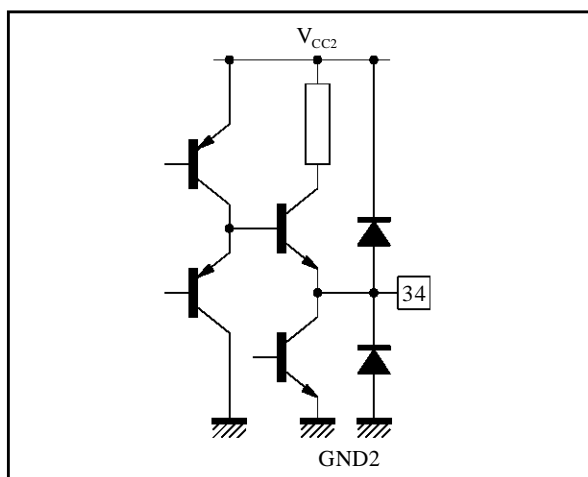

2216-33.EPS

Figure 32 : Pin 35 - VOUT

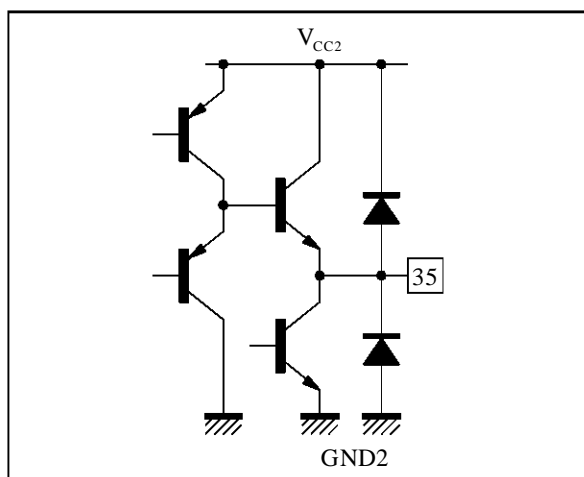

2216-34.EPS

Figure 33 : Pin 36 - HOUT

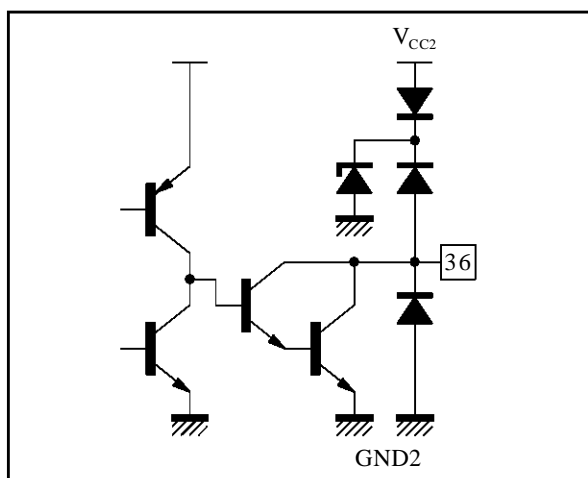

2216-35.EPS

Figure 34 : Pin 37 - LFB/SC

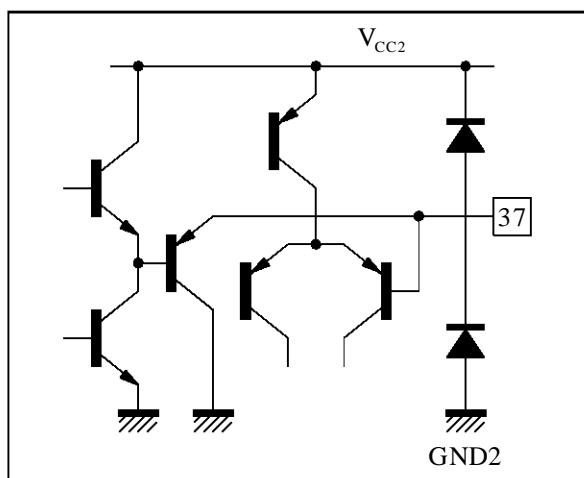

2216-36.EPS

INPUT/OUTPUT PIN CONFIGURATION (continued)

Figure 35 : Pins 38, 39 - BYI, RYI

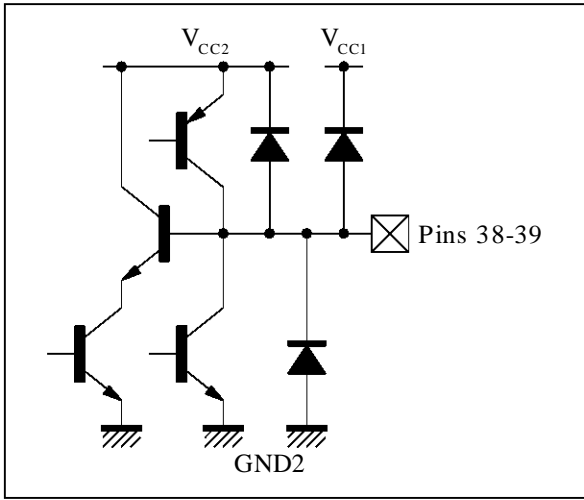

Figure 36 : Pins 40, 41 - RYO, BYO

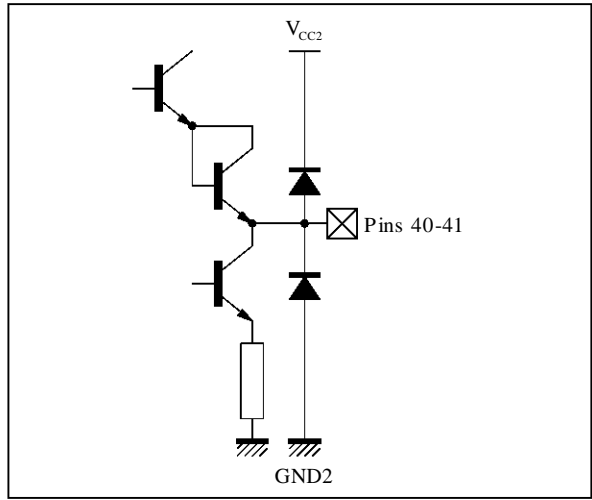
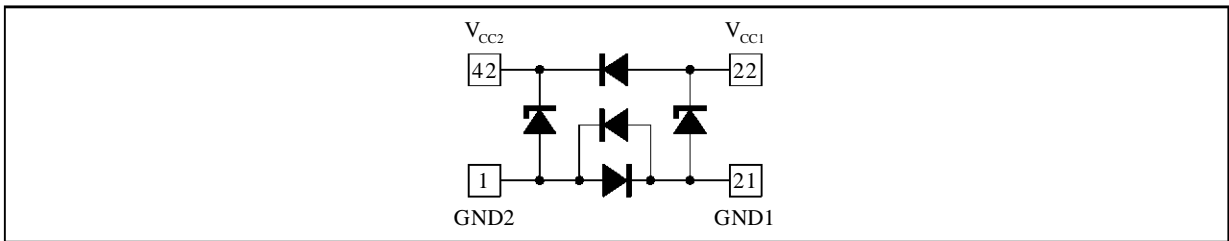
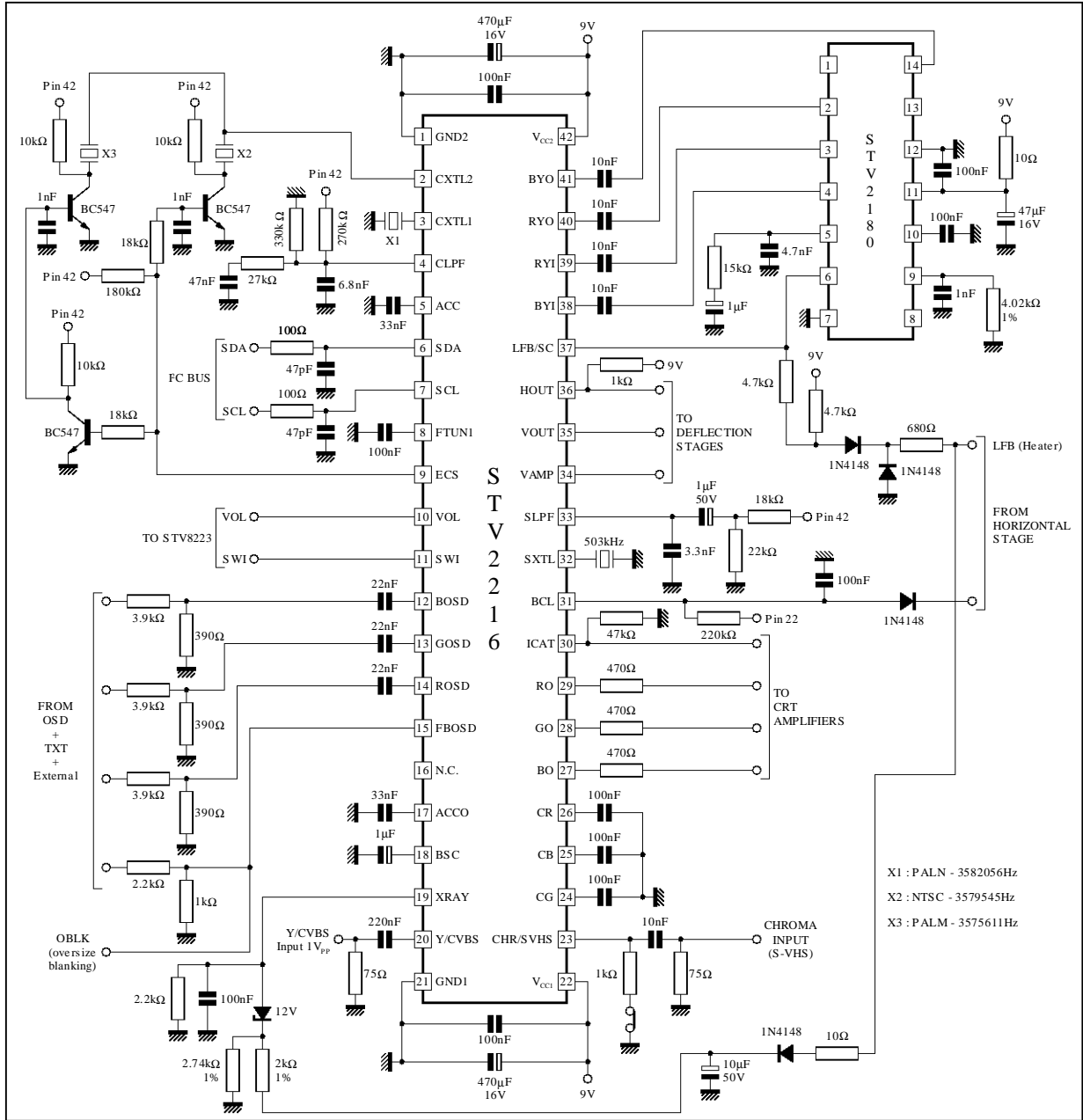

Figure 37 : Pins 42, 22 - Vcc2, Vcc1



APPLICATION DIAGRAM : PAL/NTSC 3XTALS APPLICATION



2216-40 EPS

APPLICATION DIAGRAM : 3.58MHz NTSC ONLY APPLICATION

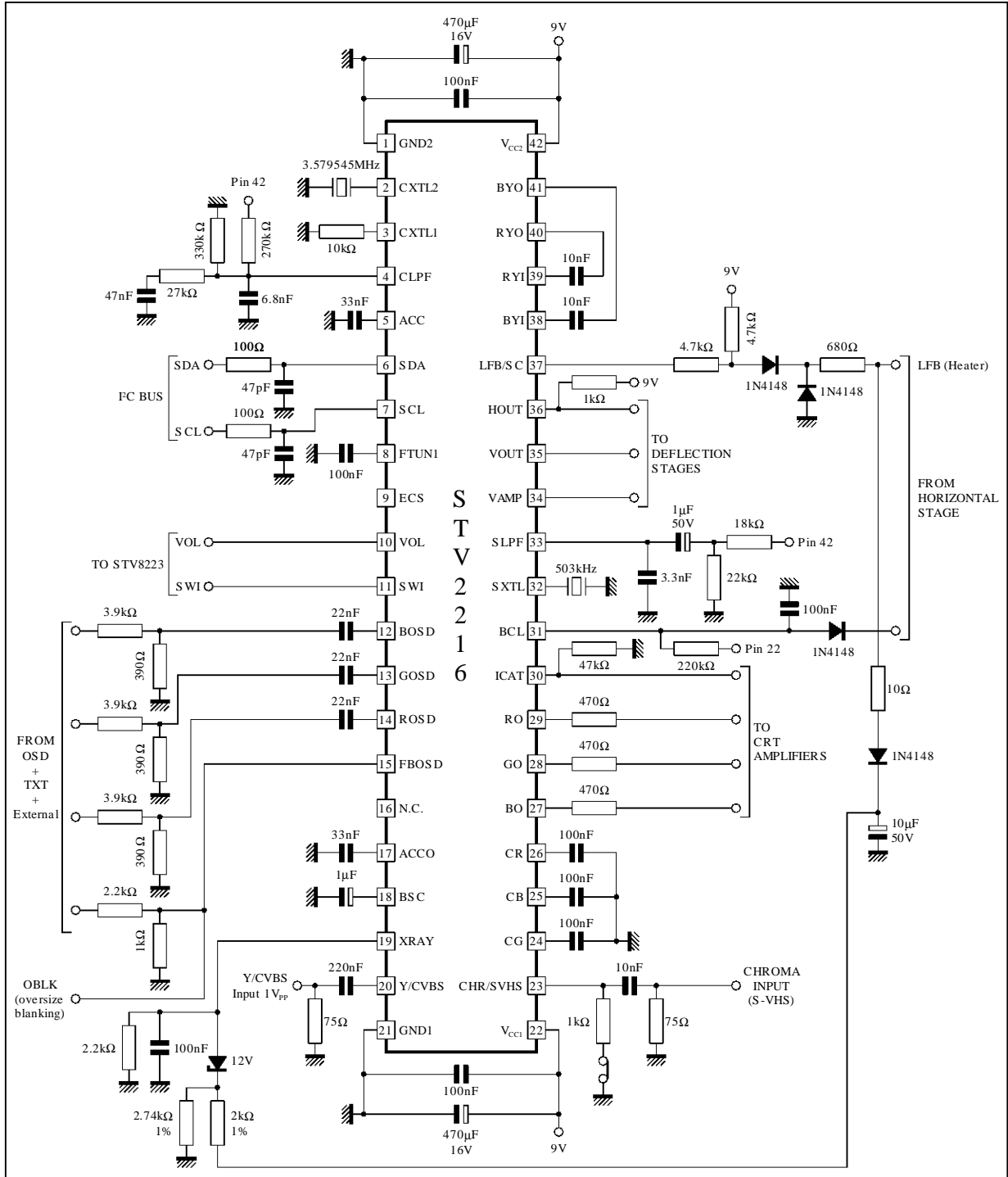

2216-41.EPS

90° CRT APPLICATIONS VERTICAL STAGE

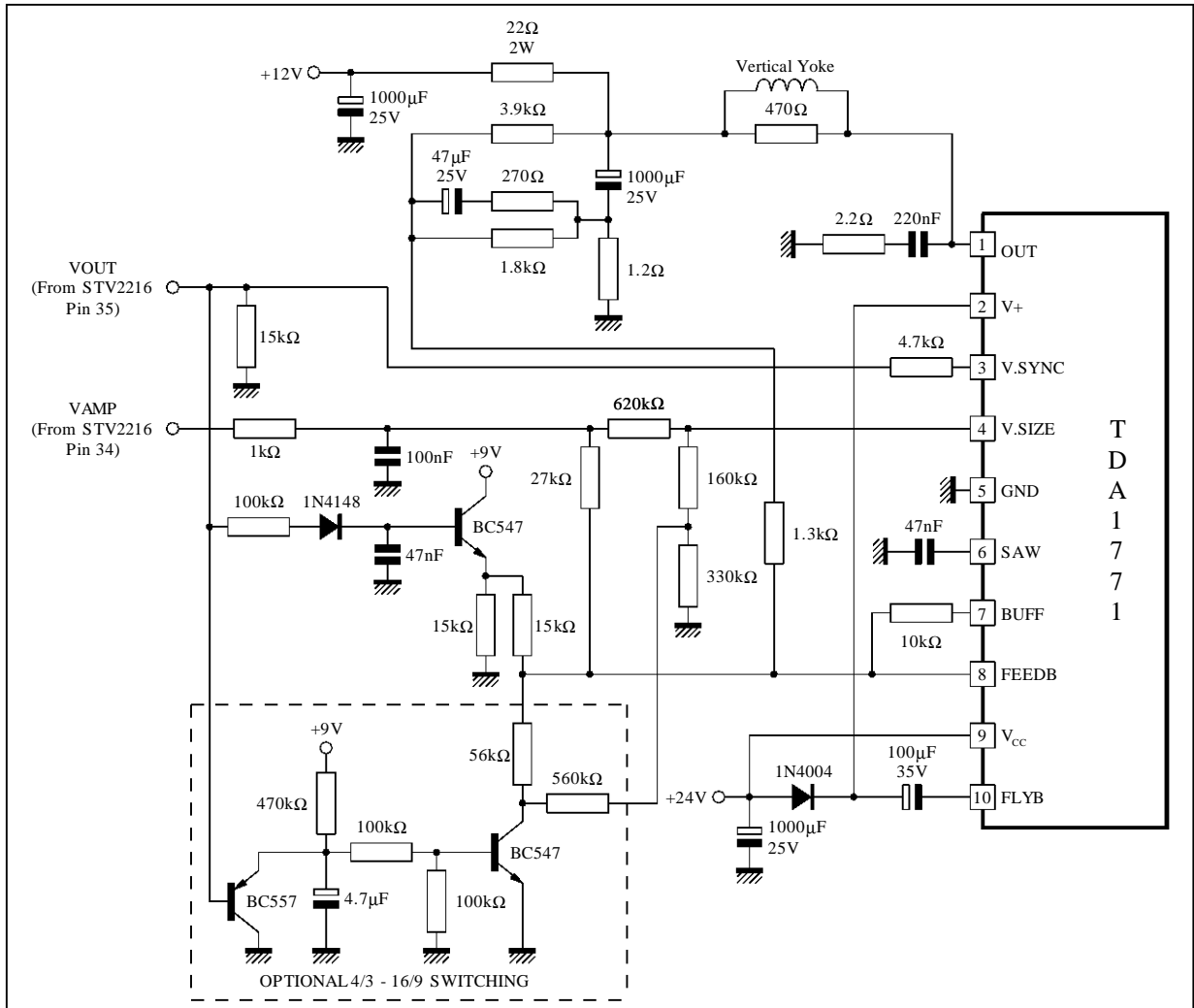

2216-42.EPS

110° CRT APPLICATIONS : Vertical System with East-West

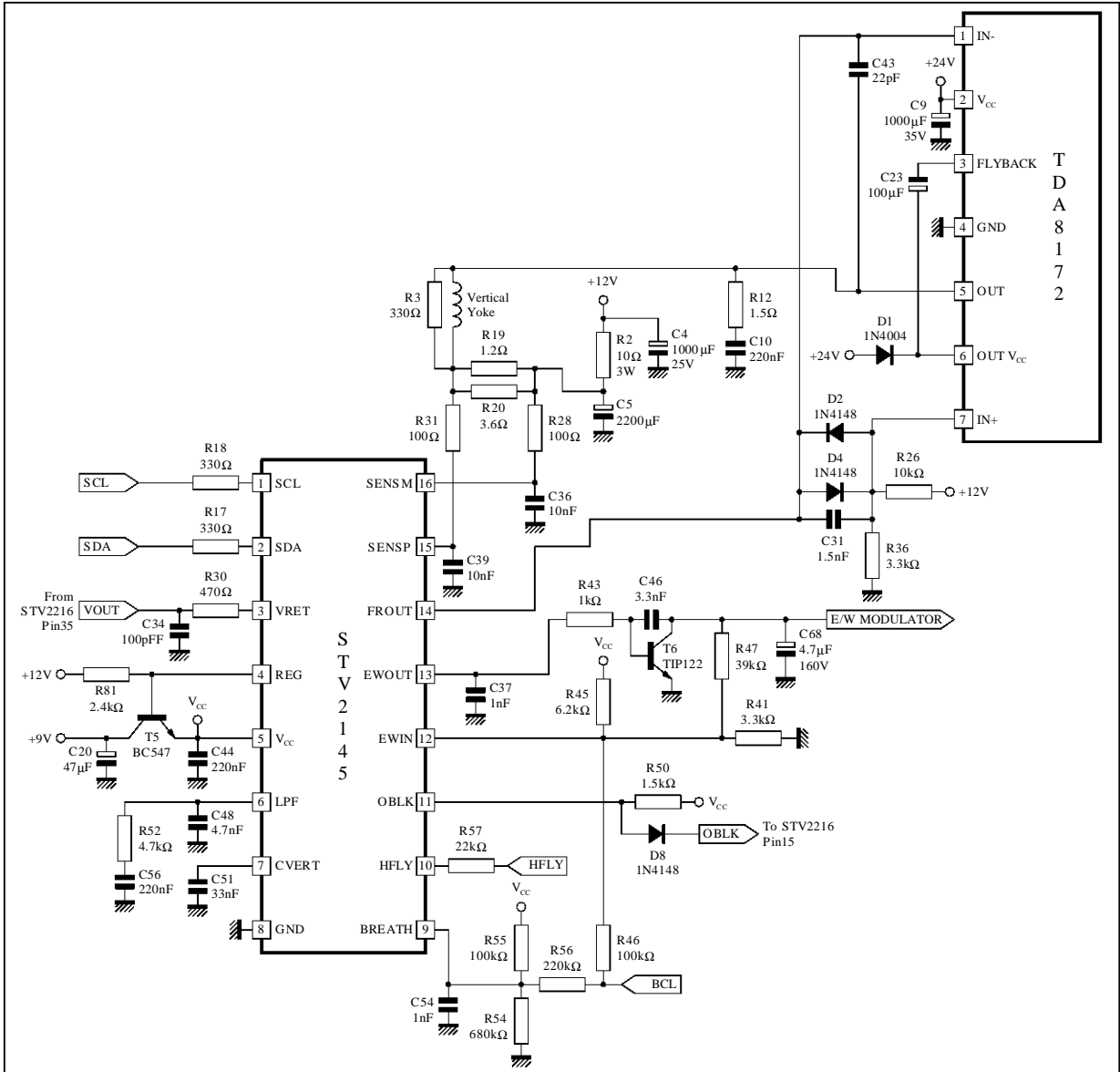

2216-43 EFS

PACKAGE MECHANICAL DATA
42 PINS - PLASTIC SHRINK DIP

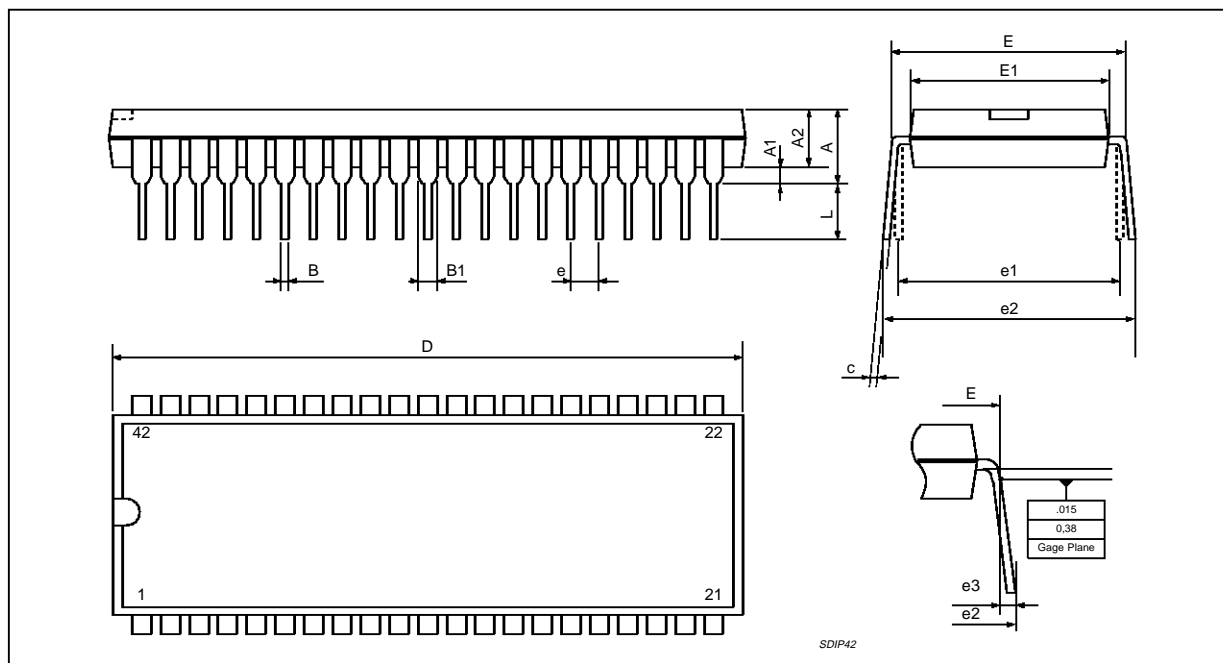

PMSDIP42.EPS

Dimensions	Millimeters			Inches		
	Min.	Typ.	Max.	Min.	Typ.	Max.
A			5.08			0.200
A1	0.51			0.020		
A2	3.05	3.81	4.57	0.120	0.150	0.180
B	0.36	0.46	0.56	0.0142	0.0181	0.0220
B1	0.76	1.02	1.14	0.030	0.040	0.045
c	0.23	0.25	0.38	0.0090	0.0098	0.0150
D	37.85	38.10	38.35	1.490	1.5	1.510
E	15.24		16.00	0.60		0.629
E1	12.70	13.72	14.48	0.50	0.540	0.570
e		1.778			0.070	
e1		15.24			0.60	
e2			18.54			0.730
e3			1.52			0.060
L	2.54	3.30	3.56	0.10	0.130	0.140

SDIP42.TBL

Information furnished is believed to be accurate and reliable. However, SGS-THOMSON Microelectronics assumes no responsibility for the consequences of use of such information nor for any infringement of patents or other rights of third parties which may result from its use. No licence is granted by implication or otherwise under any patent or patent rights of SGS-THOMSON Microelectronics. Specifications mentioned in this publication are subject to change without notice. This publication supersedes and replaces all information previously supplied. SGS-THOMSON Microelectronics products are not authorized for use as critical components in life support devices or systems without express written approval of SGS-THOMSON Microelectronics.

© 1996 SGS-THOMSON Microelectronics - All Rights Reserved

Purchase of I^2C Components of SGS-THOMSON Microelectronics, conveys a license under the Philips I^2C Patent. Rights to use these components in a I^2C system, is granted provided that the system conforms to the I^2C Standard Specifications as defined by Philips.

SGS-THOMSON Microelectronics GROUP OF COMPANIES

Australia - Brazil - China - France - Germany - Hong Kong - Italy - Japan - Korea - Malaysia - Malta - Morocco
The Netherlands - Singapore - Spain - Sweden - Switzerland - Taiwan - Thailand - United Kingdom - U.S.A.